

LOAD SERIES



**abm**  
Grinding Technologies



Full Automatic Circular Saw Production Line

**LOAD SERIES**

The flexible, advanced solution

High technology to lead the ever-changing world of tool processing.

\*Some variants are not available for German market.



**5 AXES DOUBLE WHEEL COMPLETE TOP AND FACE GRINDER IN ONE CYCLE**  
 PREMIUM is a fast, PC controlled, built in one central construction top and face grinder in one clamping. PREMIUM guarantees a smooth top and face grinding for all types of tooth profiles on T.C.T. circular saws in only one cycle.

**Top Grinding Wheel**

Type 14AA1  
 D  $\varnothing$ 150mm ( $\varnothing$ 190mm optional)  
 H  $\varnothing$ 32mm

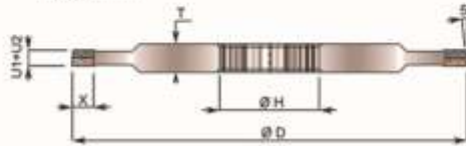

**Face Grinding Wheel**

Type 12V2  
 D  $\varnothing$ 160mm ( $\varnothing$ 200mm optional)  
 H  $\varnothing$ 32mm

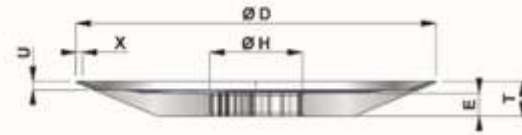

**Axes of Machine**

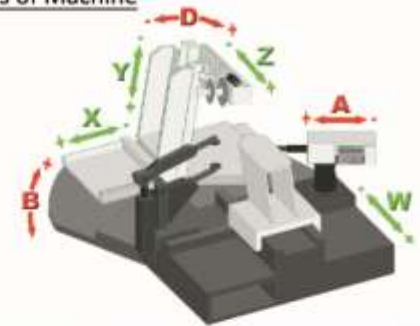

15" Touch Panel Feature



PREMIUM Grinding Wheel Screen



Measuring Probe



PREMIUM General Operating Area

## A versatile response to meet all demands...

### General Features

- Complete top and face grinding in one cycle.
- 5 axes Servo motor CNC controlled. [Axes A, B, X, Y, Z]
- Skipping the broken / missing teeth.
- Repairing the newly-replaced teeth.
- Application of two grinding wheels.
- Manual W axis to adjust the saw blade holder.
- Manual D axis for manually adjustable head bevel.
- Operating screen in any language (please state the required language while ordering)
- PC controlled.
- Windows® operating system.
- Possibility of selecting the grinding program from the control panel.
- Grinding all common tooth types in one cycle.
- Integral measuring probe.
- Automatic saw blade thickness calculation either by means of measuring probe or
- Manually entering on the control panel.
- Automatic compensation calculation by means of the measuring probe.
- Automatic kerf thickness calculation by means of a measuring probe.
- Face and top angle data collection by means of measuring probe.
- LCD screen control panel.
- Max. outside diameter  $\varnothing$ 600mm.
- Pneumatic blade clamping.
- Totally enclosed cabin for operator safety.
- Simple controls for ease of use.
- Rigid base.
- Variable grinding speed.
- Ergonomic cabin construction for ease of loading and unloading.
- Independently adjustable grinding and indexing speeds.
- Integral air suction unit.
- Oil coolant ready.
- Production conformed with CE standards.

### Technical Specifications

- Circular saw outside diameter  $\varnothing$ 150-600mm ( $\varnothing$ 800 optional)
- Bore diameter Min.  $\varnothing$ 10mm
- Blade thickness Max. 8.0mm
- Tooth pitch Max. 110mm
- Cutting angle (-10°) - (+45°)
- Max. Tangential angle +25°
- Grinding wheel outside diameter  $\varnothing$ 160mm Face/  $\varnothing$ 150mm Top
- Grinding wheel bore diameter  $\varnothing$ 32mm
- Working speed Variable from 0,5mm to 20mm/s
- Coolant motor capacity ~75lt/min.
- Coolant tank capacity ~120lt.
- Feeding rate 15 teeth/min.
- Motor quantity 8
- Connected load ~5kW
- Voltage 380V, 3Ph
- Net/gross weight 2700/2900kg
- Dimensions 200\*220\*195cm.

## 8 AXES DOUBLE WHEEL COMPLETE SIDE GRINDER IN ONE CYCLE

PREMIUM-DUO is an ideal machine for carbide-tipped circular saws production. Thanks to the CNC control, all desired geometry settings can be performed from panel. User-friendly interface and machine's ease of use minimizes the need for qualified operator. It is a high speed and high precision full CNC controlled side grinding machine. On the PREMIUM-DUO, two vertical grinding heads are adapted to our classical top and face grinding machine, the tangential and radial angles are automatically adjusted easily from the CNC Control panel:

### Side Grinding Wheel

Type 1A1F  
D  $\varnothing$ 100mm  
H  $\varnothing$ 20mm

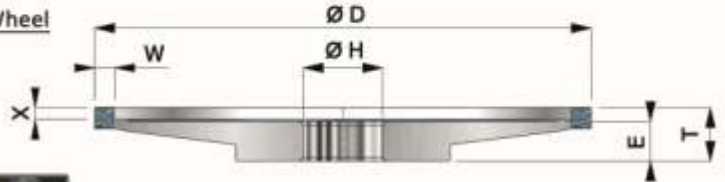

Servo Spindle System



(Variable rpm)

Axes of Machine

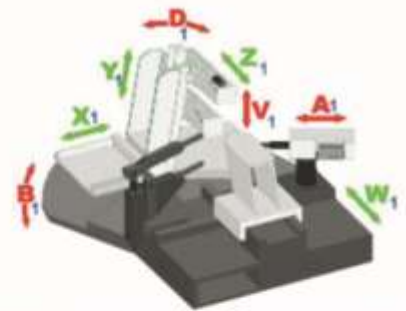

### PROGRAM

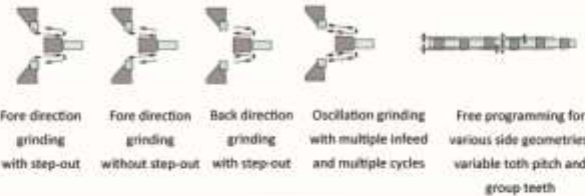

Measuring Probe  
(Renishaw)



CNC Side Grinding  
Operation

The true innovation is the product of experience and dynamics...

### General Features

- 8-axes fully CNC control.
- Special plating on mechanical components ensure non-corroding and hardening.
- Group tooth and Variable pitch indexing by intelligent finger.
- Unique software for Newly Replaced Teeth and Saw Blade Production.
- Oscillation program for multiple infeed with rough, finish amounts and finish cycles.
- 15" LCD display and operating interface in any stated language.
- Ready tooth form programs, unlimited memory for saving.
- Grinding of all types in one cycle for wood and metal industries.
- Angular or dimensional parameter input for Radial angles.
- Maximum outside diameter  $\varnothing$ 600mm.
- Clamping by Microstep motor ensures automatic clamping distance control, clamping torque control and blade thickness control to self center levels.
- Automatic tooth pitch calculation and ability manual input.
- Central lubrication system reducing maintenance and increasing machine life.
- Windows® based PC control enables update over internet or by flash drive
- Separate electrical and machine cabins provide noise, dust and heat insulation.
- Ready for oil coolant.
- Operator-friendly machine program.
- Robust base constructed in ergonomic cabin.

### Technical Specifications

- Circular Saw Outside Diameter  $\varnothing$ 150-600mm ( $\varnothing$ 800 optional)
- Bore Diameter Min.  $\varnothing$ 10 mm
- Blade Thickness Max. 8.0mm
- Tooth Pitch Max.100mm
- Grinding Angle  $(-10^{\circ}) - (+45^{\circ})$
- Max. Tangential Angle  $+35^{\circ}$
- Grinding Wheel Out. Dia.  $\varnothing$ 160mm Face/  $\varnothing$ 150mm Top( $\varnothing$ 200mm opt)
- Grinding Wheel Bore Diameter  $\varnothing$ 32mm
- Working Speed 0,5mm, 30mm/s
- Coolant Motor Capacity  $\sim$ 75lt/min.
- Coolant Container Capacity  $\sim$ 120lt.
- Feeding Rate 15 teeth/min.
- Motor Quantity 13
- Connected Load  $\sim$ 7,5kW
- Voltage 380V, 3 Phases



Operation Screen



Top Grinding Wheel



Face Grinding Wheel

PREMIUM-LOAD is designed for response of high necessities for circular saws production and grinding services. Our new generation machines minimize human labor; which robot loading system and in compact central body, face and top grinding machine are together. With high efficiency, loss of time in your workshop is prevented. Free programming for cold saw blades also enables the machine to make production for metal blades. The machine has a wide production capability of wood and metal blades.

PREMIUM-LOAD, for all teeth form of carbide circular saws in only one pass, ensure a perfect and top quality level grinding. Integral measuring probe enables high precision operation.

## Advanced grinding, to meet your demands.



Suitable for every saw bore diameter by flanges



Stations



Working Area

### General Features

- 3 carriages for loading and unloading. (Optional 5,7 stations)
- Complete top and face grinding in one cycle.
- 8 axes Servo motor CNC controlled.
- Loading and Unloading by 4 magnetic grippers.
- Repairing the newly-replaced teeth.
- Application of two grinding wheels.
- Optional Hollow Tooth Grinding Attachment
- Optional D axis driven by servo motor for face beveled blades.
- Optional Chip Breaker Attachment.
- Manual D axis for manually adjustable head bevel.
- Operating screen in any language.
- High performance periphery grinding technology.
- PC controlled.
- Windows® operating system.
- Possibility of selecting the grinding program from the control panel.
- Grinding all common tooth types in one cycle.
- Integral measuring probe.
- Automatic saw blade thickness calculation either by means of measuring probe or manually entering on the control panel.
- Automatic compensation calculation by means of the measuring probe.
- Automatic kerf thickness calculation by means of a measuring probe.
- Face and top angle data collection by means of measuring probe.
- 15" touch screen control panel.
- Max. outside diameter Ø600mm.
- Pneumatic blade clamping.
- Totally enclosed cabin for operator safety.
- Simple controls for ease of use.
- Rigid base.
- Variable grinding speed.
- Ergonomic cabin construction for ease of loading and unloading.
- Independently adjustable grinding and indexing speeds.
- Integral air suction unit.
- Oil coolant ready.
- Production conformed with CE standards.

## Axes of Machine

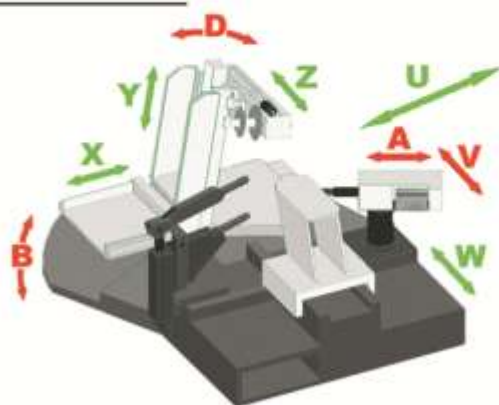

## GRINDING WHEELS

### Face Grinding Wheel

Type 12V2  
 D  $\varnothing$ 160mm ( $\varnothing$ 200mm optional)  
 H  $\varnothing$ 32mm

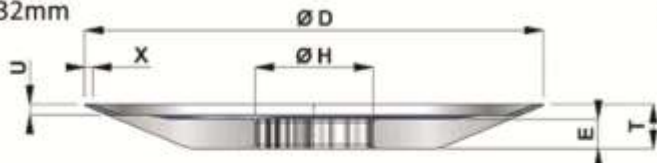

### Top Grinding Wheel

Type 14AA1  
 D  $\varnothing$ 150mm ( $\varnothing$ 190mm optional)  
 H  $\varnothing$ 32mm

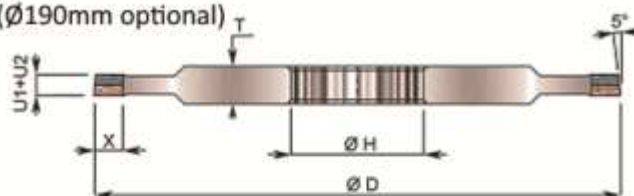

## Motors on the Machine

	Power (kW)	Revolution (RPM)	Feeding Voltage	Additional Features
Axis X (Servo)	0.75	3000	-	Absolute encoder-with brake
Axis Y (Servo)	0.75	3000	-	Absolute encoder-with brake
Axis Z (Servo)	0.75	3000	-	Absolute encoder-with brake
Axis A (Servo)	0.75	3000	-	Absolute encoder-without brake
Axis B (Servo)	0.75	3000	-	Absolute encoder-with brake
Axis U (Servo)	0.75	3000	-	Absolute encoder-with brake
Axis V (Servo)	0.75	3000	-	Absolute encoder-without brake
Axis W (Servo)	0.75	3000	-	Absolute encoder-with brake
Grinding wheel motor	1.1	2900	380V-3phases	
Coolant motor	0.75	2800	380V-3phases	
Air suction motor	0.37	2800	230V-1phase, 50Hz	

The true innovation is the product of experience and dynamics...



General operating screen

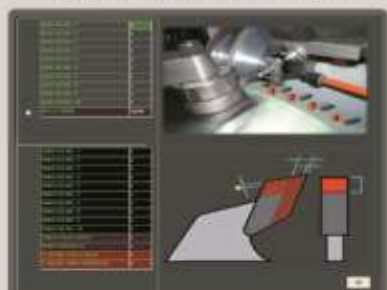

Broken tooth and repair tooth screen



Parameter screen

## Technical Specifications

- Circular saw outside diameter  $\varnothing$ 150-600mm ( $\varnothing$ 800 optional)
- Post diameter  $\varnothing$ 30 mm (Replaceable posts)
- Loading Carriage 3 Carriages
- Loading Capacity 50 Saw Blades
- Air Pressure Required Minimum 6 Bars
- Cutting angle (-7°) - (+45°)
- Max. Tangential angle +25°
- Grinding wheel outside diameter  $\varnothing$ 160mm
- Grinding wheel bore diameter  $\varnothing$ 32mm
- Working speed Variable from 0,5mm to 20mm/s
- Coolant motor capacity 75lt/min.
- Coolant tank capacity ~120lt.
- Feeding rate 0-25 teeth/min.
- Motor quantity 11
- Connected load ~6.8kW
- Voltage 380V, 3Ph



Top Grinding



Face Grinding



Side Grinding

LOAD-5 is designed for response of high necessities for circular saws production with full CNC control systems. Our new generation machines finish human labor; which robot loading system and in compact central body, face and top grinding on Premium machine and side grinding on Premium-DUO machine. With high efficiency and precision.

LOAD-5, for all teeth form of TCT circular saws in only one pass, ensure a perfect production.

## A versatile response to meet all demands...

### General Features

- 5 stations for loading and unloading.
- Ability to stack saw blades in Mixed-Order of various diameters and tooth forms by reducer rings.
- Complete saw blade production in one set-up.
- 15 axes Servo motor CNC controlled. Smart servo system with position memory.
- Loading and Unloading by 4 magnetic grippers.
- Optional Hollow Tooth Grinding Attachment
- Optional D axis driven by servo motor for beveled face grinding.
- Manual D axis for manually adjustable head bevel.
- Operating screen in any language (please state the required language in purchase order)
- PC controlled.
- Windows® operating system.
- Possibility of selecting the variable grinding programs from the control panel.
- Grinding all common tooth types in one cycle.
- Integral measuring probe.
- Automatic saw blade thickness calculation either by means of measuring probe or manually entering on the control panel.
- Automatic compensation calculation by means of the measuring probe.
- Automatic kerf thickness calculation by means of a measuring probe.
- Face and top angle data collection by means of measuring probe.
- LCD screen control panel.
- Max. outside diameter Ø600mm.
- Pneumatic blade clamping.
- Totally enclosed cabin for operator safety.
- Simple controls for ease of use.
- Rigid base.
- Variable grinding speeds at different set-ups.
- Ergonomic cabin construction for ease of loading and unloading.
- Independently adjustable grinding and indexing speeds.
- Integral air suction unit.
- Automatic Lubrication Unit.
- Live Tracking by internet connection from anywhere with internet connection.
- Oil coolant ready.
- Production conformed with CE standards.

### Technical Specifications

- Circular saw outside diameter  $\varnothing$ 150-600mm (Optional  $\varnothing$ 800 mm)
- Post diameter (Changeable)  $\varnothing$ 30 mm
- Loading Carriage 5 Carriages
- Air Pressure Required Minimum 6 Bars
- Cutting angle (0°) - (+45°)
- Radial angle (-50°) - (+45°)
- Max. Tangential angle +25°
- Working speed Variable from 0,5mm to 20mm/s
- Coolant motor capacity 55lt/min.
- Coolant tank capacity ~120lt.
- Feeding rate 15-25 teeth/min.
- Motor quantity 21
- Connected load ~14.0 kW
- Voltage 380V, 3Ph
- Net/gross weight 7625/7750kg
- Dimensions 725\*170\*240cm



Live assistance and Cam Tracking



Loading Process

## Axes of Machine

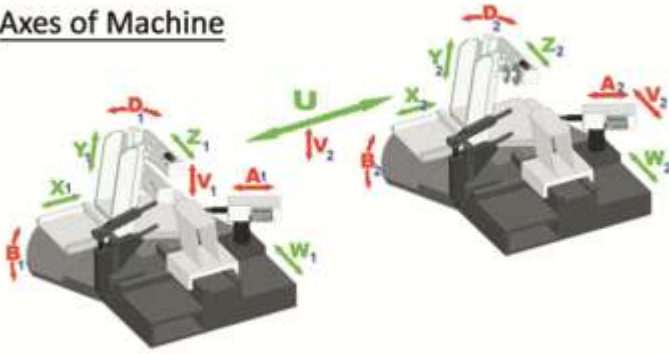

## Motors on the Machine

Motors	Power (kW)	Revolution (RPM)	Amount	Additional Features
Axis X (Servo)	0.75	3000	2 pieces	Absolute encoder-with brake
Axis Y (Servo)	0.75	3000	2 pieces	Absolute encoder-with brake
Axis Z (Servo)	0.75	3000	2 pieces	Absolute encoder-with brake
Axis A (Servo)	0.75	3000	2 pieces	Absolute encoder-without brake
Axis B (Servo)	0.75	3000	2 pieces	Absolute encoder-with brake
Axis U (Servo)	0.75	3000	1 piece	Absolute encoder-with brake
Axis V (Servo)	0.75	3000	2 pieces	Absolute encoder-with brake
Axis W (Servo)	0.37	3000	2 pieces	Absolute encoder-with brake
Grinding wheel motor	1.1	2900	2 pieces	
Coolant motor	0.75	2800	2 pieces	
Air suction motor	0.14	2800	2 pieces	

## GRINDING WHEELS

### Face Grinding Wheel

Type 12V2  
 D Ø160mm  
 (optional Ø200mm)  
 H Ø32mm

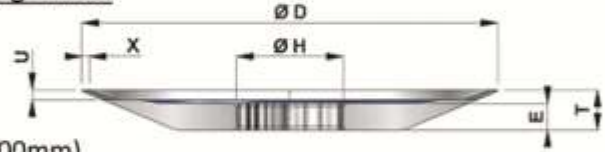

### Face Grinding Wheel

Type 14AA1  
 D Ø150mm  
 (optional Ø190mm)  
 H Ø32mm

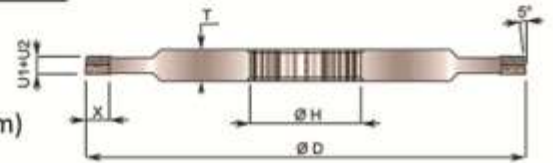

### Side Grinding Wheel

Type 1A1F  
 D Ø100mm  
 H Ø20mm

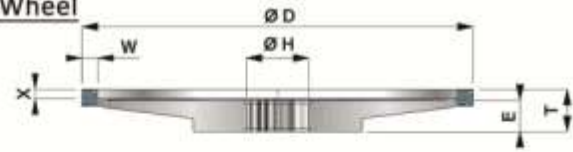

The true innovation is the product of experience and dynamics...

## LOAD-5 PD800 Side Grinding and Face/Top Grinding Machines Line (16 AXES)

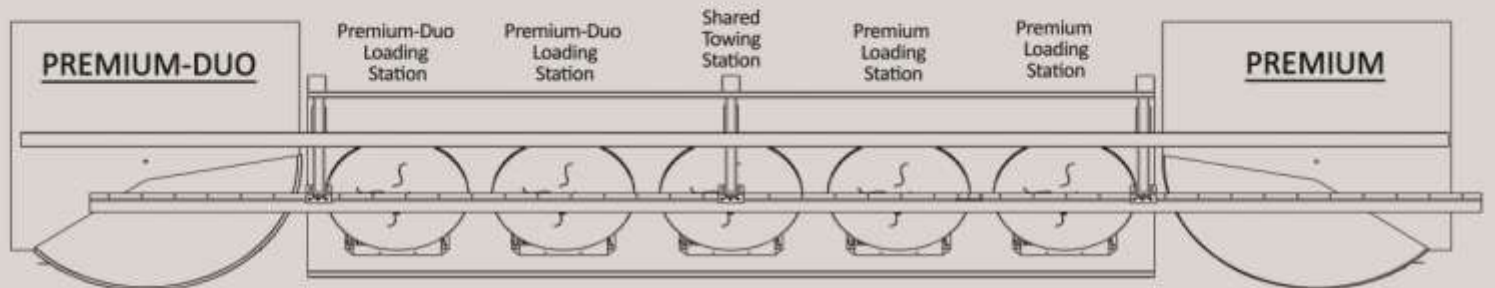

## LOAD-5 PP800 2 Units Face/Top Grinding Machines Line (14 AXES)

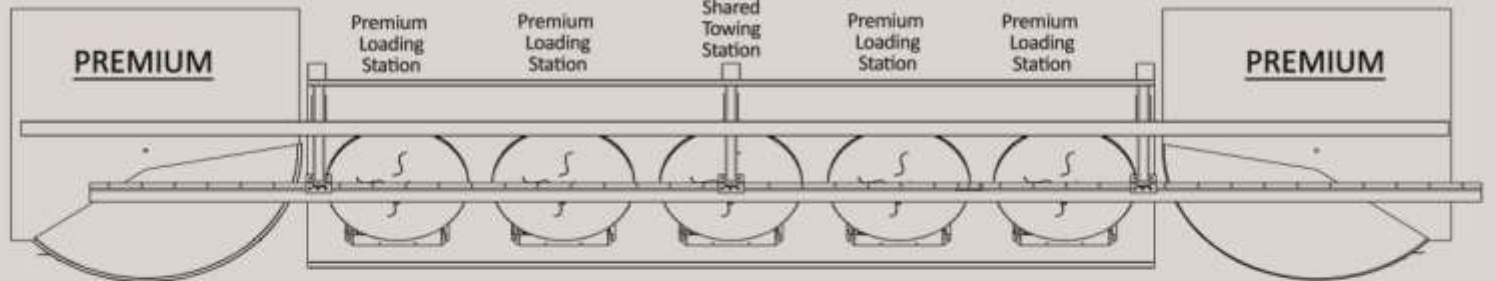

## LOAD-5 DD800 2 Units Side Grinding Machines Line (17 AXES)

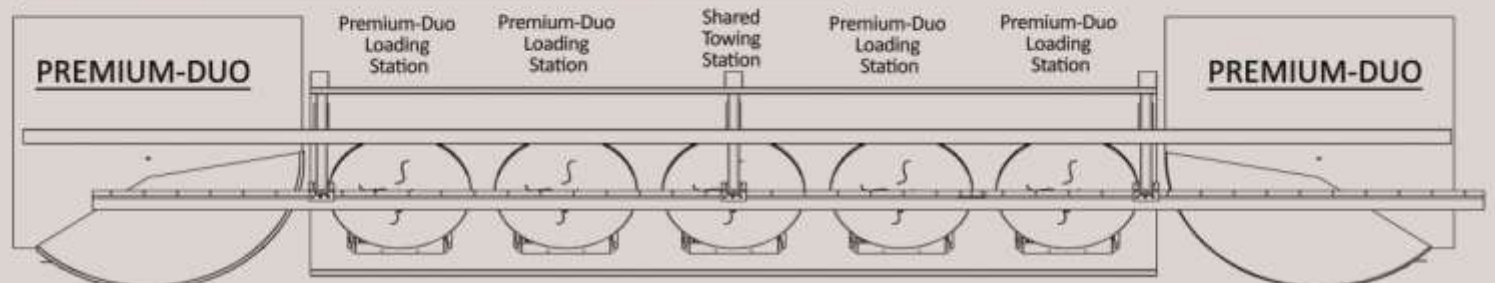



# abm

**Grinding Technologies**



*Our path on grinding technologies production started in 1965, continues applying all modern technologies on our services. Not only in local market, our machines are working world-wide nearly 150 countries.*



İTOB 10011 Sok. No:6 Tekeli, 35477, Menderes, İzmir, TÜRKİYE  
Phone: +90 232 782 6644 /1468 Fax: +90 232 782 2390  
www.abmmakine.com • info@abmmakine.com

